

The A880 rectifier diode features a nominal 77mm silicon junction diameter design, manufactured by the proven multi-diffusion process. High reverse voltage blocking capability is optimized with moderate recovery current and low forward voltage.

A880 is designed specifically for transportation, industrial and utility 50/60 Hz rectifiers having very high current surge and I²t requirements.

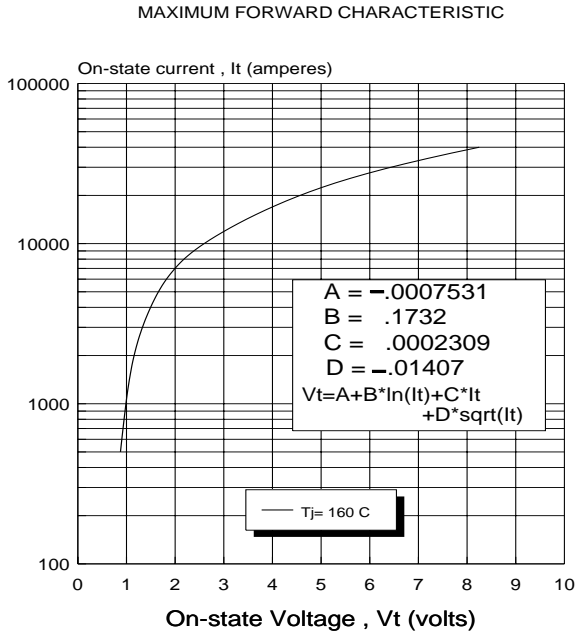

91B/A880onst

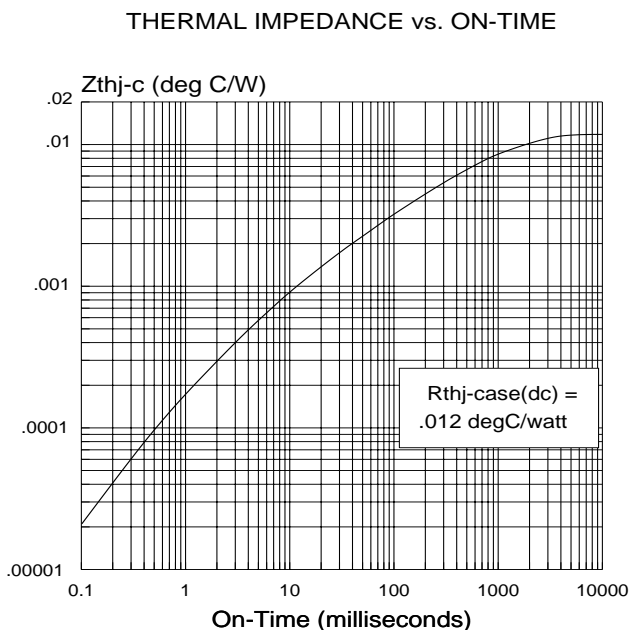

SELECTION TABLE

Model No.	Repetitive Peak Reverse Voltage	
	$V_{RRM} @ T_J = -40\text{ to }170^\circ\text{C}$	$V_{RRM} @ T_J = 200^\circ\text{C}$
A880DE	4500 V	3900 V
A880DD	4400	3800
A880DC	4300	3700
A880DB	4200	3600
A880DA	4100	3500
A880DP	4000	3400
A880CT	3900	3300
A880CN	3800	3200

MECHANICAL OUTLINE

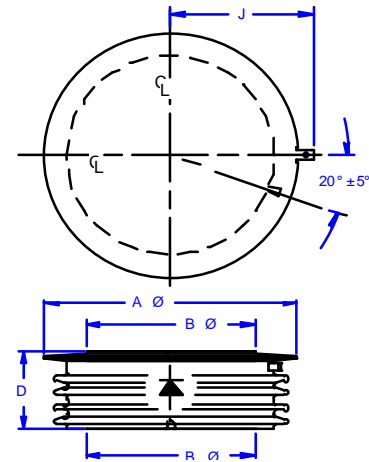

$A \Phi = 4.35\text{ in (110.5 mm)}$
 $B \Phi = 2.88\text{ in (73.2 mm)}$
 $D = 1.45\text{ in (36.8 mm)}$

CLAMPING FORCE REQUIRED
7000 - 9000 lb / 31.1 - 40.0 kN

LIMITING CHARACTERISTICS AND RATINGS

PARAMETER	SYMBOL	TEST CONDITIONS	MAX. VALUES	UNITS
Average current	I_{AV}	half sine $T_c = 100^\circ\text{C}$	2900	A
Repetitive peak reverse voltage	V_{RRM}	$T_j = -40$ to $+170^\circ\text{C}$ 50/60 Hz	see page 1	V
Repetitive peak reverse current	I_{RRM}	$T_j = 170^\circ$ 25°	100 15	ma
Forward voltage	V_{FM}	$T_j = 160^\circ$ $I_F = 2000\text{A}$	1.15	V
Non-rep peak surge current	I_{FSM}	$T_j = 160^\circ$ $t_p = 8.3\text{ms}$ $t_p = 10\text{ms}$ $V_R = 0$	40 36	kA

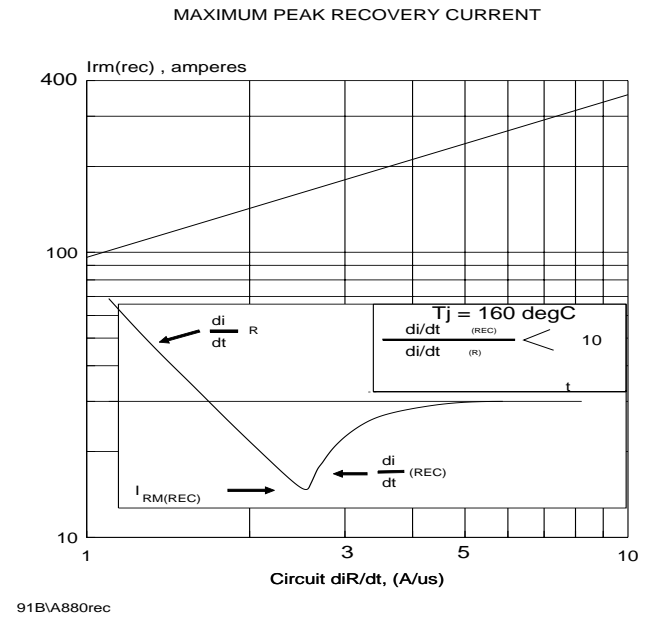

POWER DISSIPATION
Full Cycle Average

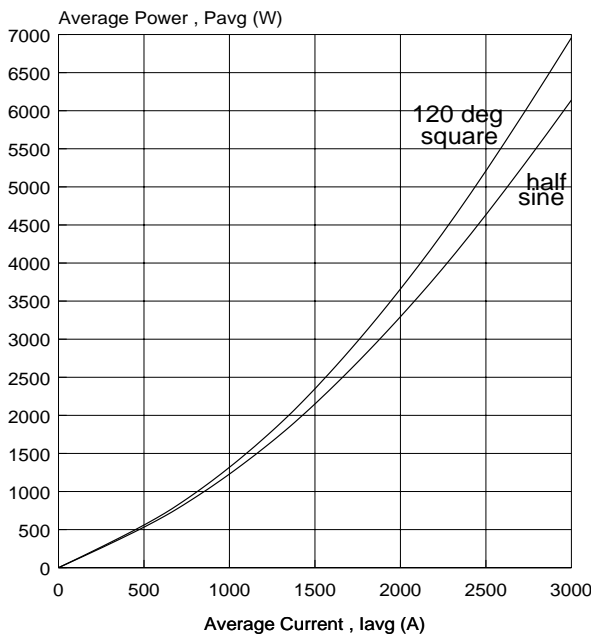

AVERAGE POWER DISSIPATION

$T_j = 160 \text{ degC}$

I_{AV} (A)	half sine	120° sq. wave
500	509	533
750	841	891
1000	1221	1308
1250	1651	1786
1500	2132	2327
2000	3251	3602
2500	4585	5155
3000	6139	6958