

INVERTER THYRISTOR

C458

53mm / 1400V / 2000Arms / 35us

Type C458 reverse blocking thyristor is suitable for inverter applications. The silicon junction is manufactured by the all-diffused process and utilizes the field-proven, interdigitated amplifying gate structure. It is supplied in an industry accepted disc-type package, ready to mount using commercially available heat dissipators and mechanical clamping hardware.

ON-STATE CHARACTERISTICS

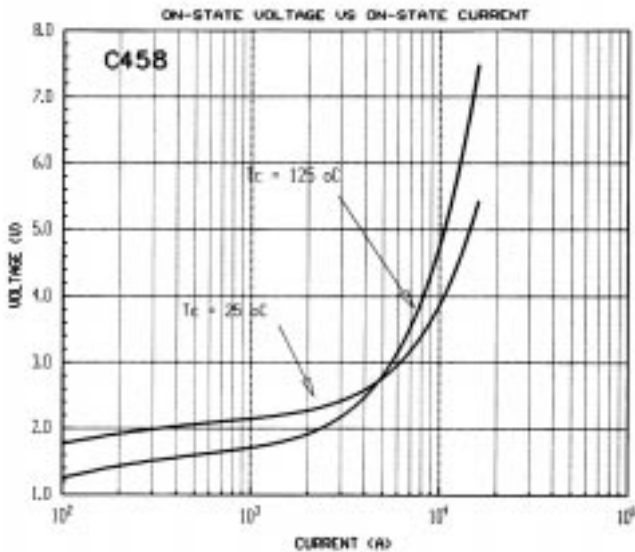

THERMAL IMPEDANCE

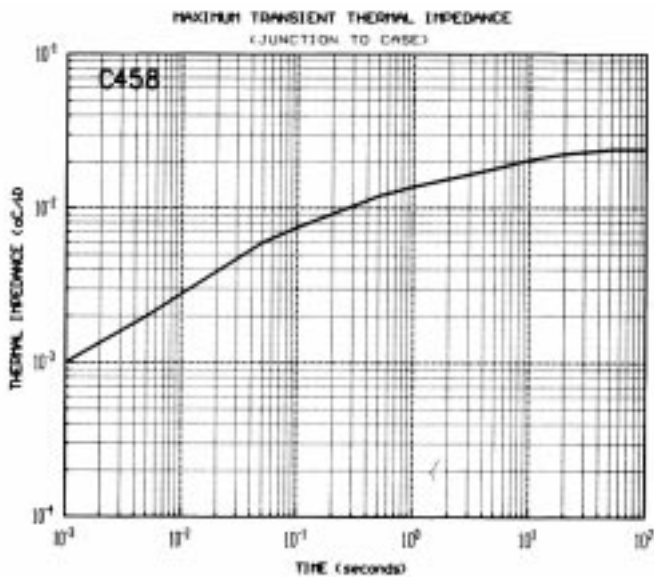

MODEL	V_{DRM} / V_{RRM} 0 to +125°C	@ -40°C
C458PD	1400	1300
C458PB	1200	1100
C458P	1000	900

Gate Drive Requirements:
 20 V / 20 ohms / 0.5us risetime
 5 - 10 us minimum duration
 External Clamping Force
 5000 - 6000 lbs.
 24.5 - 26.7 kN

MECHANICAL OUTLINE

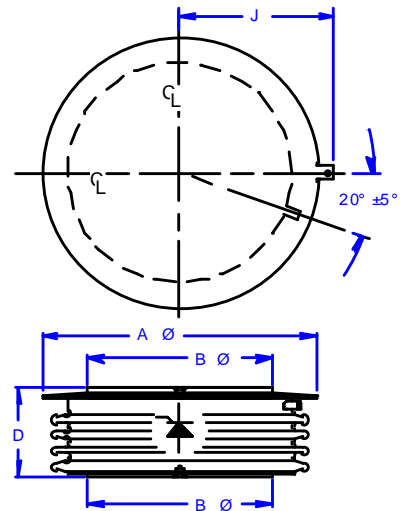

$A \Phi = 2.96$ in (75.2 mm)
 $B \Phi = 1.90$ in (48.3 mm)
 $D = 1.07$ in (27.2 mm)

SILICON POWER CORPORATION
 175 GREAT VALLEY PKWY. MALVERN, PA 19355
 USA

LIMITING CHARACTERISTICS

PARAMETER	SYMBOL	TEST CONDITIONS	LIMIT	UNITS
Repetitive peak off-state & reverse voltage	V_{DRM}/V_{RRM}	$T_j = -40$ to $+125^\circ\text{C}$	up to 1400V	volts
Off-state & reverse current	I_{DRM}/I_{RRM}	$T_j = 125^\circ\text{C}$	65	ma
Peak half cycle non-repetitive surge current	I_{TSM}	60Hz (8.3ms) 50Hz (10ms)	16 14.6	kA
For fusing	I^2t	8.3ms	1.06	MA ² s
On-state voltage	V_{TM}	$I_T = 4000\text{A}$ $t_p = 8.3\text{ms}$ $T_j = 25^\circ\text{C}$	2.6	volts
Critical rate of rise of on-state current	di/dt_{rep}	$V_D = 60\% V_{DRM}$ 60Hz $T_j = 125^\circ\text{C}$	400	A/us
Critical rate of rise of off-state voltage	dv/dt	$V_{DCRIT} = 80\% V_{DRM}$ $T_j = 125^\circ\text{C}$	500	v/us
Reverse recovery charge	Q_{RR}	$I_T = 1000\text{A}, T_j = 125^\circ\text{C}$ $V_R > -50\text{V}$ @ 100A/us	400	uC
Circuit commutated turn-off time	t_Q	200V/us to $80\% V_{DRM}$ $V_r = -50\text{V}$	35	us

